

# **LDG RT-100 100-Watt Remote Automatic Tuner**



## **LDG Electronics**

1445 Parran Road  
St. Leonard MD 20685-2903 USA

Phone: 410-586-2177

Fax: 410-586-8475

[ldg@ldgelectronics.com](mailto:ldg@ldgelectronics.com)

[www.ldgelectronics.com](http://www.ldgelectronics.com)

## Table Of Contents

<b>Introduction</b>	<b>3</b>
<b>Jumpstart, or “Real hams don’t read manuals!”</b>	<b>3</b>
<b>Specifications</b>	<b>4</b>
<b>An Important Word About Power Levels</b>	<b>4</b>
<b>Important Safety Warning</b>	<b>4</b>
<b>Getting to know your RT-100</b>	<b>5</b>
<i>RT-100 Connections</i>	<b>6</b>
<b>Installation</b>	<b>7</b>
<i>Basic Installation</i>	<b>7</b>
<i>Installing Into An Existing Outdoor Antenna Installation</i>	<b>8</b>
<b>Operation</b>	<b>9</b>
<i>Basic Tuning Operation</i>	<b>9</b>
<i>Fully Automatic Memory Tuning</i>	<b>9</b>
<i>Force a Full Tuning Cycle</i>	<b>9</b>
<i>Re-tuning Prohibition</i>	<b>9</b>
<i>MARS/CAP Coverage</i>	<b>10</b>
<b>The LDG RT-100</b>	<b>10</b>
<b>A Word About Tuning Etiquette</b>	<b>11</b>
<b>Care and Maintenance</b>	<b>11</b>
<b>Technical Support</b>	<b>11</b>
<b>Two-Year Transferrable Warranty</b>	<b>11</b>
<b>Out Of Warranty Service</b>	<b>12</b>
<b>Returning Your Product For Service</b>	<b>12</b>
<b>Product Feedback</b>	<b>13</b>

## INTRODUCTION

LDG pioneered the automatic, wide-range switched-L tuner in 1995. From its laboratories in St. Leonard, Maryland, LDG continues to define the state of the art in this field with innovative automatic tuners and related products for every amateur need.

Congratulations on selecting the RT-100 100-watt remote automatic tuner. The RT-100 provides full- and semi-automatic antenna tuning across the entire HF spectrum plus 6 meters, at power levels up to 100 watts. It will tune dipoles, verticals, Yagis, or virtually any coax-fed antenna. It will match an amazing range of antennas and impedances, far greater than some other tuners you may have considered, including the built-in tuners on many radios.

The RT-100 is similar to previous LDG tuners, but is powered over coax, so that the tuner element may be placed as near to the antenna as possible. The tuner element is powered over the coax feedline by means of a built-in bias tee, so no additional cables are required in order to place the tuner at the antenna end of the feedline. By placing the tuner as close to the antenna as possible, SWR losses over the length of the feedline are minimized.

The optional RC-100 control unit for the RT-100 provides DC power injection via a bias tee, as well as a convenient on/off switch, power indicator, and TUNE button, which momentarily interrupts power to the RT-100.

## JUMPSTART, OR “REAL HAMS DON’T READ MANUALS!”

Ok, but at least read this one section before operating the RT-100:

1. Turn off power to your radio.
2. Connect the antenna jack on the transceiver to the “Radio” jack on the optional RC-100 or the “RF” jack of a bias tee (not included).
3. Connect the “Tuner” jack of the optional RC-100 or “RF+DC” jack of a bias tee to the “Radio” jack on the RT-100, via your antenna’s existing feedline.
4. Connect the antenna to the “Ant” jack on the RT-100.
5. Connect a source of 12VDC, 500mA to the Power jack on the optional RC-100 or the bias tee.
6. Begin transmitting; the tuner will automatically begin tuning if there is an SWR mismatch.

## SPECIFICATIONS

- 0.1 to 100 watts SSB and CW peak power, 75W on digital modes and 6 meters.
- Latching relays for ultra low power operation.
- 2,000+ memories for instantaneous frequency and band changing.
- Power: 12VDC, 500mA, extracted from the coax feedline via built-in bias tee. (DC injection bias tee not included)
- 1.8 to 54.0 MHz coverage.
- Tunes 4 to 800 ohm loads (16 to 150 on 6M), 16 to 3200 ohms with optional 4:1 Balun.
- For Dipoles, Verticals, Vees, Beams or any Coax Fed Antenna.
- Optional external Balun allows tuning of random length, long wire or ladder line fed antennas.
- Optional RC-100 controller provides DC power injection, On/Off switch, and Tune button.
- Dimensions:
  - xxx”L x xxx”W x xxx”H.
- Weight:
  - xxx lb, xxx oz.

## AN IMPORTANT WORD ABOUT POWER LEVELS

The RT-100 is rated at 125 watts maximum power input *at most*. Many ham transmitters and transceivers, and virtually all amplifiers, are capable of transmitting well over 125 watts. Power levels that significantly exceed specifications will definitely damage or destroy your RT-100. If your tuner fails during overload, it could also damage your transmitter or transceiver. Be sure to observe the specified power limitations.

### IMPORTANT SAFETY WARNING

**Never install antennas or transmission lines over or near power lines. You can be seriously injured or killed if any part of the antenna, support or transmission line touches a power line. Always follow this antenna safety rule: the distance to the nearest power line should be at least twice the length of the longest antenna, transmission line or support dimension.**

## GETTING TO KNOW YOUR RT-100

Your RT-100 is a quality, precision instrument that will give you many years of outstanding service; take a few minutes to get to know it.

The RT-100 tuner is designed to be used as a remote antenna tuner, powered over a single coax cable that carries both the RF energy and DC power. An on-board bias tee separates the RF from the DC power. In order to power the RT-100, a separate bias tee must be used to inject DC power at the feed end of the coax. Alternately, the optional RC-100 RT-100 Controller unit may be used. It contains not only a DC bias tee for injecting power, but also an Off/On power button, LED power indicator, and a Tune button which momentarily interrupts power to the RT-100.

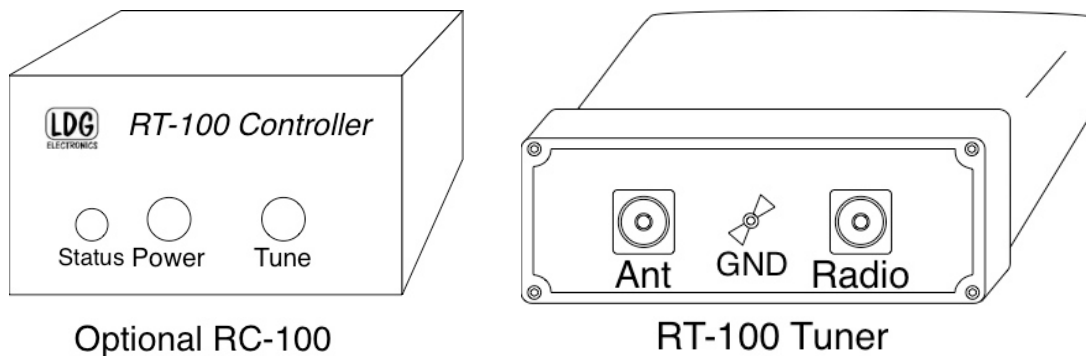

The RT-100 is powered via 12VDC, which is supplied over the same coax cable used for the antenna feedline. A bias tee or optional RC-100 is needed at the radio end of the cable, to inject DC power onto the feedline. Because power is supplied over coax, the existing coax feedline to your antenna is all you need to hook up the RT-100. No additional cables are required in order to run power or control signals to the tuner.

The RT-100 has 2,000 frequency memories. When tuning on or near a previously tuned frequency, the RT-100 uses “Memory Tune” to recall the previous tuning parameters in a fraction of a second. If no memorized settings are available, the tuner runs a full tuning cycle, storing the parameters for memory recall on subsequent tuning cycles on that frequency. In this manner, the RT-100 “learns” as it is used, adapting to the bands and frequencies as it goes. The RT-100’s latching relays hold the tuned configuration indefinitely, even when DC power is completely removed. Tuning memories are stored in FLASH memory.

*RT-100 Connections*

The RT-100 has three connectors:

- **ANT SO-239:** Output to the antenna. Connect the antenna to this SO-239.
- **GND (wingnut):** Connect to antenna system ground.
- **Radio SO-239:** Connect to the feedline which comes from the optional RC-100 or bias tee.

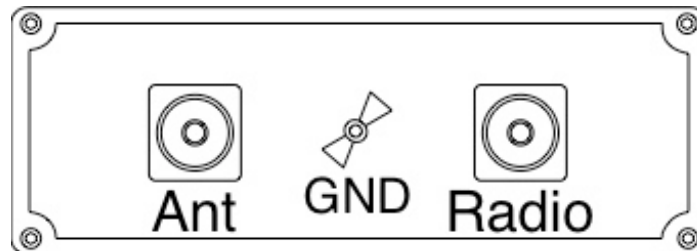

## INSTALLATION

The RT-100 tuner is designed for outdoor operation; it is waterproof. However, LDG recommends using silicone coax sealing tape on the coax connections after installation, to ensure water stays out of the connections.

The RT-100 is designed for use with coax-fed antennas. If use with longwires or ladder-line-fed antennas is desired, an external balun is required.

Always turn your radio off before plugging or unplugging anything. The radio may be damaged if cables are connected or disconnected while the power is on.

### *Basic Installation*

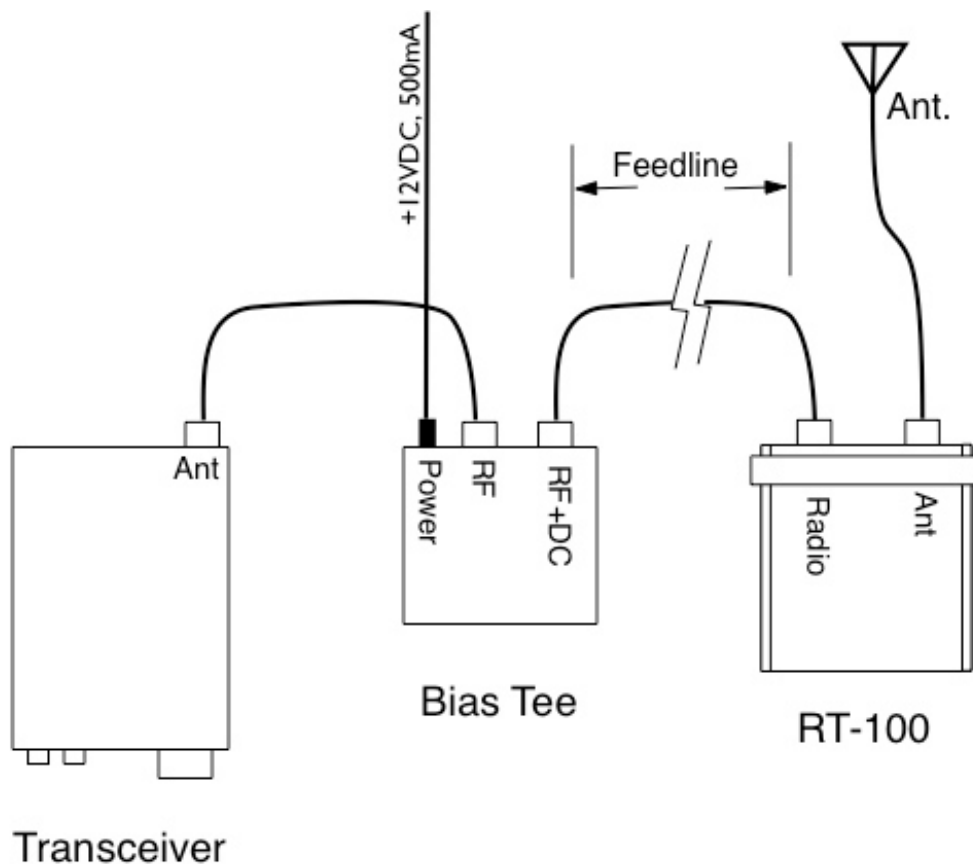

To install the RT-100 system, place the a bias tee in a convenient position near the transceiver's operating position. Connect a 50-ohm coax jumper from the transceiver's Antenna jack to the bias tee's **RF** jack. For installation using the optional RC-100 controller, see the RC-100's user manual.

Place the RT-100 Tuner near to the antenna. Connect a short 50-ohm coax jumper from the RT-100 Tuner's **ANT** jack to the antenna. Connect the RT-100 Tuner's **RADIO** jack to the bias tee's **RF+DC** jack via a length of coaxial cable feedline. LDG recommends grounding the RT-100 Tuner via the wingnut marked **GND**.

Connect the bias tee to a source of 12VDC power, 500 mA.

**NOTE:** The RT-100 has no SWR display. If your transceiver does not have a built-in SWR display, you will need to put an external SWR meter in between the output of the transceiver and the input of the bias tee:

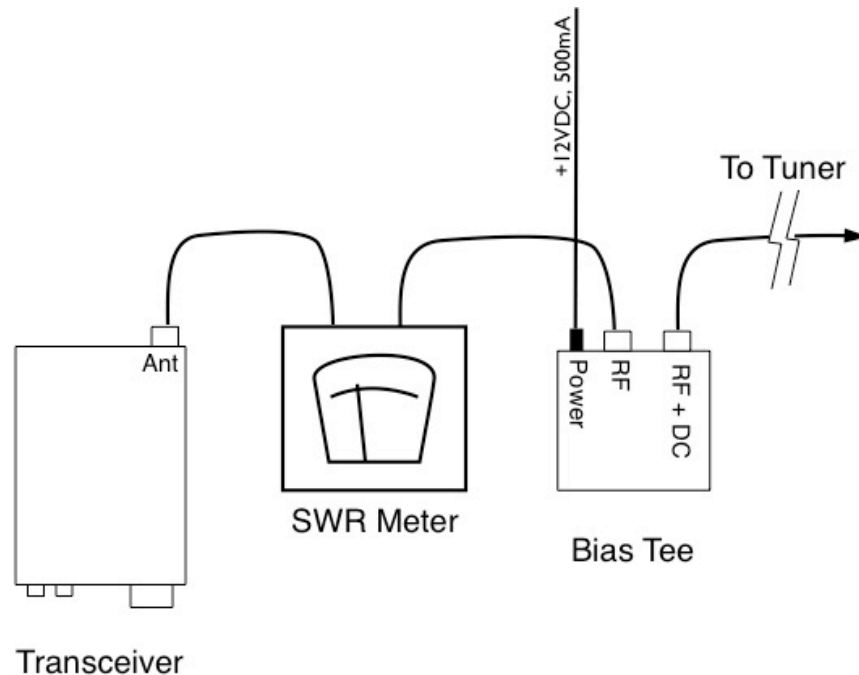

#### *Installing Into An Existing Outdoor Antenna Installation*

The RT-100 is designed to allow you to easily upgrade your existing outdoor antenna installation to one with a remote tuner at the antenna end of the feedline. Because the RT-100 receives its power and control signals over the coax, it is not necessary to run any additional cables. Simply unhook the existing antenna from the antenna end of the feedline, and connect that end of the feedline to the RT-100's **RADIO** jack. Now connect a short coax jumper from the RT-100's **ANT** jack to the antenna.

At the radio end of the feedline, disconnect the feedline from the radio, and connect it to the **RF+DC** jack on a bias tee. Now connect a short coax jumper from the transceiver's TX jack to the **RF** jack on the bias tee, and connect DC power.



## OPERATION

### *Basic Tuning Operation*

Two types of tuning cycles are available; a memory tuning cycle and a full tuning cycle.

The **memory tuning cycle** attempts to tune quickly based on having previously tuned on the present frequency selection. If the tuner previously was successful in tuning on the currently selected frequency, the settings for that match will be loaded into the tuner relays, and checked to see that an acceptable SWR match is found. If this fails to find a good SWR match, then a full tuning cycle begins.

A **full tuning cycle** “starts from scratch” and begins a fixed tuning sequence where the RT-100 rapidly tries varying combinations of inductance and capacitance values, and then zeroes-in on the best match possible. When the tuning cycle is complete, if an acceptable match was found, the inductance and capacitance settings are saved in a memory associated with the selected frequency, so that they may be recalled quickly in the future via a memory tuning cycle.

In this manner, the RT-100 “learns”; the longer you use it, the more closely it adapts itself to the bands and frequencies used.

Whenever the RT-100 is powered up, it is in fully automatic Memory Tuning mode. This means that any time RF is present, if the SWR detected is too high, a memory tuning cycle will automatically begin.

Most users will probably use memory tuning most of the time; it takes advantage of any saved tuning settings, but automatically defaults to a full tuning cycle if no stored data is available.

### *Fully Automatic Memory Tuning*

In order to begin a fully automatic memory tuning cycle, simply tune the radio to the band and frequency desired, and, while the RT-100 is powered on, simply begin transmitting. If a high SWR condition is detected, the RT-100 Tuner will begin tuning. To watch the progress of the tuning cycle, keep an eye on your radio’s built-in SWR meter (or external SWR meter, if applicable). The SWR needle will jump around for a bit and then will settle down to a low SWR value. Once this happens, tuning is complete. If the tuner is tuning on a previously memorized frequency, the tuning cycle will only last for a short instant while memory settings are recalled.

### *Force a Full Tuning Cycle*

In some instances, you may wish to force the RT-100 to begin a full tuning cycle instead of just the usual memory cycle. In order to do this, turn off power to the RT-100 (do this by switching off power to the bias tee), begin transmitting a carrier, and while still keying the radio, turn on power to the bias tee. Continue transmitting the tuning carrier until the SWR settles to a low value.

### *Re-tuning Prohibition*

In some rare cases, when an antenna is tuned far from its resonant frequency, the RT-100 may erroneously continue to attempt to re-tune, even though it has already found a good match for the

current antenna and frequency. In these cases, if the RT-100 decided to re-tune after it has already found a good match, simply turn the RT-100 off, by removing power from the bias tee. The latching relays inside the tuner will keep the current match settings even with power off, but the tuner will stop attempting to re-tune.

### *MARS/CAP Coverage*

The RT-100 provides continuous tuning coverage over its specified range; not just in the ham bands. This makes it useful for MARS or CAP operation, or any other legal HF operation.

## **THE LDG RT-100**

In 1995, LDG Electronics pioneered a new type of automatic antenna tuner. The LDG design uses banks of fixed capacitors and inductors, switched in and out of the circuit by relays under microprocessor control. An additional relay switches between high and low impedance ranges. A built-in SWR sensor provides feedback; the microprocessor searches the capacitor and inductor banks, seeking the lowest possible SWR. The tuner is a "Switched L" network, consisting of series inductors and parallel capacitors. LDG chose the L network for its minimum number of parts and its ability to tune unbalanced loads, such as coax-fed dipoles, verticals, Yagis, and, in fact, virtually any coax-fed antenna.

The series inductors are switched in and out of the circuit, and the parallel capacitors are switched to ground under microprocessor control. The high/low impedance relay switches the capacitor bank either to the transmitter side of the inductor bank, or to the antenna side. This allows the RT-100 to handle loads that are either greater than or less than 50 ohms. All relays are sized to carry 100 watts continuously.

The SWR sensor is a variation of the Bruene circuit. This SWR measuring technique is used in most dual-meter and direct-reading SWR meters. Slight modifications were made to the circuit to provide voltages instead of currents for the analog-to-digital converters that provide signals proportional to the forward and reflected power levels. The single-lead primary through the center of the sensor transformer provides RF current sampling. Diodes rectify the sample and provide a DC voltage proportional to RF power. These two voltages are read by the ADCs in the microprocessor, and are used to compute SWR in real time.

The relays are powered by the 12VDC supplied over the coax cable via a bias tee. The bias tee allows both RF and DC to be carried over the same conductor.

Although the microprocessor's oscillator runs at 32 MHz, which allows the main tuning routine to execute in only a few milliseconds, the relays require several milliseconds of settling time for every combination of inductors and capacitors. Thus, it may take several seconds before all relay combinations are exhausted, in the case of a difficult tune.

The tuning routine uses an algorithm to minimize the number of tuner adjustments. The routine first de-energizes the high/low impedance relay if necessary, then individually steps through the inductors to find a coarse match. With the best inductor selected, the tuner then steps through the individual capacitors to find the best coarse match. If no match is found, the routine

repeats the coarse tuning with the high/low impedance relay energized. The routine then fine tunes the inductors and capacitors. The program checks LC combinations to see if a 1.5:1 or lower SWR can be obtained, and stops when it finds a good match.

The microprocessor runs a fine tune routine just after the tuner finds a match of 1.5:1 or less. This fine tune routine now tries to get the SWR as low as possible (not just to 1.5); it takes about half a second to run.

### **A WORD ABOUT TUNING ETIQUETTE**

Be sure to use a vacant frequency when tuning. With today's crowded ham bands, this is often difficult. However, causing interference to other hams should be avoided as much as possible. The RT-100's very short tuning cycle minimizes the impact of tuning transmissions.

### **CARE AND MAINTENANCE**

The RT-100 tuner is essentially maintenance-free. Power limits in this manual should be strictly adhered to. The outer case may be cleaned as needed with a soft cloth slightly dampened with household cleaning solution. As with any modern electronic device, the RT-100 can be damaged by temperature extremes, impact, or static discharge. LDG strongly recommends the use of a good quality, properly installed lightning arrestor in the antenna lead.

### **TECHNICAL SUPPORT**

The LDG customer support staff is ready to answer your product question by telephone and by e-mail. We know that you will enjoy your product even more knowing LDG is ready to answer your questions as the need arises.

LDG regularly updates on-line information so the best on-line support information is available all day and every day.

The LDG website provides links to product manuals, just in case you lose this one! When you are thinking about the purchase of other LDG products our website also has complete product specifications and photographs you can use to help make your purchase decision. Don't forget the links to all of the quality LDG Dealers also ready to help you make that purchase decision.

### **TWO-YEAR TRANSFERRABLE WARRANTY**

Your product is warranted against manufacturer defects in parts and labor for two full years from the date of purchase. This two-year warranty is also transferable. When you sell or give away your LDG product, give the new owner a copy of the original sales receipt and the two-year warranty goes with the new owner.

There is no need to complete a warranty card or to register an LDG product. Your product receipt establishes eligibility for warranty service, so save that receipt. Send your receipt with the

product whenever you send your product to LDG for repair. Products sent to LDG without a receipt are considered requests for out-of-warranty repair.

LDG does not warranty against product damage or abuse. This means that a product failure, as determined by LDG, to be caused by the customer or by other natural calamity (e.g. lightning) is not covered under the two-year warranty. Damage can be caused by failure to heed the product's published limitations and specifications or by not following good Amateur practice.

### **OUT OF WARRANTY SERVICE**

If a product fails after the warranty period, LDG wants to help you get it fixed. Send the product to us for repair any time you like. We will determine what needs to be done and based on your instructions, either contact you with an estimate or fix it and contact you with a request to pay any repair charges. Please contact LDG if you have any questions before you send us an out-of-warranty product for repair.

### **RETURNING YOUR PRODUCT FOR SERVICE**

Returning a product to LDG is easy. We do not require a return merchandise authorization, and there is no need to contact LDG to return your product. Visit the LDG web site and download the LDG Product Repair Form. On the Repair Form tell the LDG technicians exactly what happened or didn't happen and why you believe the product needs servicing. The technician attempts to duplicate the problem(s) you had based on how well you describe it so take the time to be accurate and complete.

Ask your shipper for a tracking number or a delivery verification receipt. This way you know the product arrived safely at LDG. Be sure to give us your email address so our shipper can alert you online when your product is en-route back to you. Please be assured that our staff makes every effort to complete repairs ahead of our published wait time. Your patience is appreciated.

Repairs can take six to eight weeks, but are usually faster. The most recent information on returning products for service is found on the LDG website under Support, then Tech Support. Send your carefully packaged unit with the Repair Form to:

LDG Electronics, Inc.  
Attn: Repair Department  
1445 Parran Rd  
St. Leonard, MD 20685

**PRODUCT FEEDBACK**

We encourage product feedback! Tell us what you really think of your LDG product. In a card, letter, or email (preferred) tell us how you used the product and how well it worked in your application. Send along a photo or even a schematic or drawing to illustrate your narrative. We like to share your comments with our staff, our dealers, and even other customers at the LDG website:

<http://www.ldgelectronics.com/>

